



MULTI PURPOSE AMPLIFIED SPEAKER CABINETS

**2-WAY, BI-POWERED SPEAKER CABS
SMS8P, SMS10P, SMS12P, SMS15P**



**2-WAY, ACTIVE POWERED SPEAKER CABS W/ MP3 READER:
SMS12PLCD, SMS 15PLCD**



IMPORTANT SAFETY INSTRUCTIONS

READ AND KEEP THESE INSTRUCTIONS. HEED ALL WARNINGS.

- This active speaker system must be connected to a mains (AC) outlet to work properly and must be earthed to operate safely.
- Ensure that correct AC mains voltage and socket - fitted with a real ground connection – are available before powering up the unit.
- Check mains power cable and plugs before switching on the equipment.
If the mains cable and/or plug are damaged, replace the whole cable immediately.
For your own and other people's safety, never repair or modify the mains power cable.
Dispose of the defective cable properly for waste and recycling purpose.
- After following the instructions outlined above, if your powered speaker fails to function, please contact your vendor.
Under no circumstances should the cabinet be opened. Leave all servicing to qualified personnel.
- Electrical appliances must never be used in conditions of high humidity or heat.
To prevent any risk of fire or electric shock, never spill or splash liquids on the amplifier.
Should this happen, unplug the power cable from the mains outlet and switch off the powered speaker immediately.
- May we draw your attention to the instructions printed on the rear panel of the cabinet.

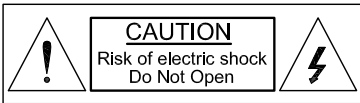

CAUTION:
TO REDUCE THE RISK OF
FIRE, REPLACE ONLY WITH
THE SAME TYPE OF FUSE.
DISCONNECT POWER
SUPPLY CORD BEFORE
CHANGING FUSE.

WARNING: Exposure to extremely high noise levels may cause permanent hearing damage. Please use this amplified speaker responsibly for you and your neighbourhood.

MARKING & CONFORMITY

- The CE mark on this product means it conforms to the EMC Directive (2004/108/CE), CE marking Directive (93/68/EEC) and Low Voltage Directive (2006/95/EC).
- The "Crossed-out Wheelie Bin" is to draw your attention to the WEEE (Waste Electric & Electronic Equipment) Directive (2002/96/EC). It means this apparatus must be collected separately for recycling.
- "RoHS compliant" means this device conforms to the (2002/95/EC) Directive on the restriction of the use of certain hazardous substances in electrical and electronic equipment, such as: Mercury, Lead, Cadmium, Hexavalent Chromium, Polybrominated Buphenyl (PBB) and Polybrominated Diphenyl Ethers (PBDE).



FOREWORD

Thank you for purchasing your new Stagg SMS Powered Speaker Cabinet.

Stagg SMS series powered speakers with integral mixer section are designed as multi purpose tools with output powers ranging from true 90 to 220 Watts RMS, making them ideal as stand alone (mini) PA systems or as part of larger amplification systems when connected to a mixing console, additional powered speaker(s) or any other PA equipment.

Stagg SMS8P/10P/12P and 15P models are bi-amplified models featuring an electronic crossover and two separate output power stages, one driving a powerful 8", 10", 12" or 15" Woofer to thoroughly reproduce low and mid end frequencies, the second one linked to a compression horn tweeter for accurate high end frequencies reproduction.

Stagg SMS12PLCD and 15PLCD models are active speaker cabinets equipped with one mono, large band, power amplifier combined to a passive cross-over that splits the audio signal range in two separate ways: one to the 12" or 15" Woofer for the low and medium frequencies, the other one to the compression horn tweeter for the high frequencies.

SMS12/ 15PLCD models also come with a built-in MP3 player section including USB and SD card inputs, LC Display, front selectable push switches and remote control.

MECHANICAL FEATURES

Each Stagg SMS series powered speaker features a sturdy compression horn tweeter with wide Titanium diaphragm (1), a rugged, woofer with heavy Ferrite magnet and large voice coil, protected by a resistant, metallic grille (2), all housed in a heavy-duty ABS nylon fibre cabinet with built-in pole mount socket (4) with locking screw (8) for use with a tripod-style stand, rubber feet (3) on the bottom for portable applications, corresponding stacking notches (5) for stacking purposes and rigging points (6) on the top, bottom, and rear of the cabinet for permanent and flight installations, and integral, ergonomic carrying handle (7) for easy transportation.

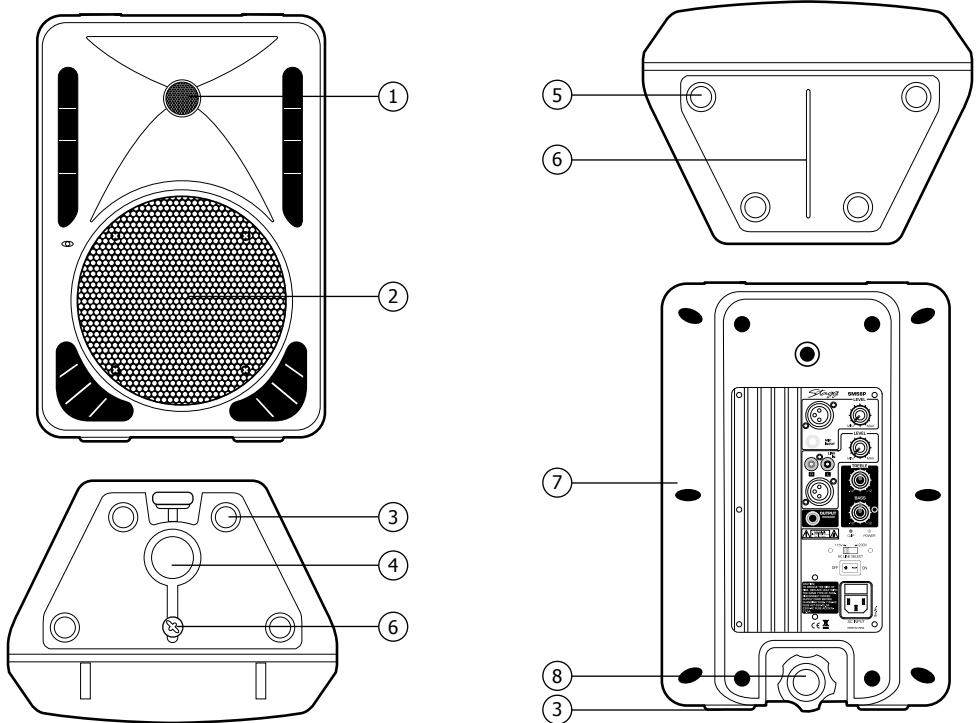

STAGG SMS8P

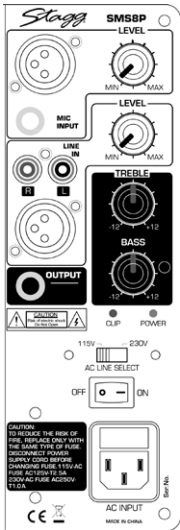

STAGG SMS10P



STAGG SMS12P



STAGG SMS15P

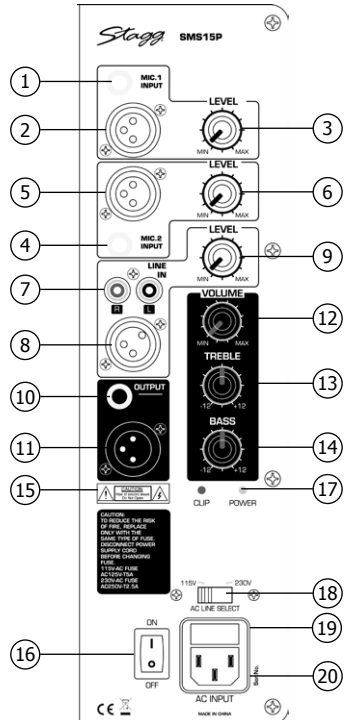

STAGG SMS12PLCD

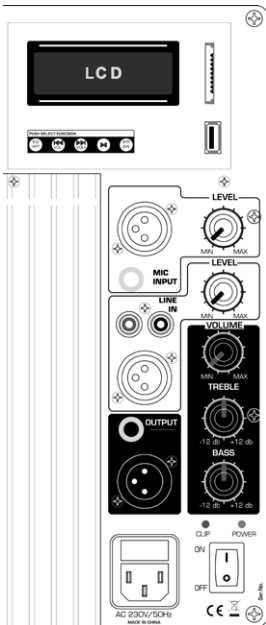

STAGG SMS15PLCD

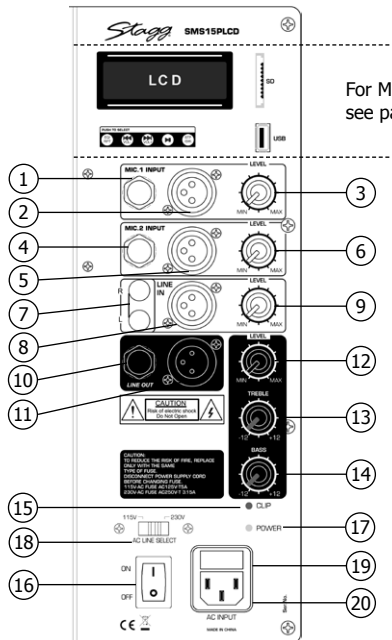

For MP3 Player, see page 6

MIC CHANNEL

1. JACK INPUT – This high impedance, ¼" stereo jack socket accepts unbalanced vocal microphones or passive instruments with high impedance transducers or pick ups, such as electric or electro-acoustic (bass) guitar, electric violin, electric double bass etc. We recommend the use of a high-quality shielded guitar cable to prevent any background noise interference or unwanted feedback.

2. XLR INPUT– This low impedance, balanced XLR socket is designed to connect a low impedance dynamic microphone. This can be a vocal mic for a singer or a speaker, or alternatively an instrument mic to amplify an all-acoustic instrument that does not feature an onboard preamp system. You may also use this input to plug in an electro-acoustic instrument with a balanced output signal. Wiring of the 3-pin connector is: Pin 1= Shield; Pin 2 = Positive (Hot); Pin 3 = Negative (Cold).

3. (Mic) LEVEL – This control determines the output level for both Jack and XLR inputs of the MIC channel.

4. (Jack In), 5. (XLR In), 6. (Mic Level) – Only the SMS15P model features a second, identical MIC channel to connect more microphones or instruments as described in paragraphs 1., 2. & 3.

LINE CHANNEL

7. (L + R) INPUTS – This line level, RCA/ Phono (RCA/ Cinch) sockets are provided for connecting stereo audio sources such as: CD/MP3/ Tape players, or musical instruments with line level outputs, i.e: rhythm machines, samplers, electronic keyboards, synthesizers etc. Left and Right inputs are linked together for monophonic use.

8. XLR INPUT – This line level, balanced XLR connector is designed to only accept signals from line level equipment with balanced output such as a tape machine, a mixing console, or another (Stagg SMS) Powered Speaker Cabinet. When the distance between the external audio device and the powered speaker cabinet exceeds 15 feet, a balanced cable should preferably be used to minimise signal loss. Wiring of the 3-pin connector is: Pin 1= Shield; Pin 2 = Positive (Hot); Pin 3 = Negative (Cold).

9. (Line) LEVEL – This control adjusts the output level for both Jack and XLR inputs of the LINE channel.

OUTPUT SECTION

10. JACK OUT - This ¼" stereo jack socket features a line level, pre EQ, balanced output to connect the unit to a sound mixer, an additional (Stagg SMS) Powered Speaker Cabinet or any other (mini) Power Amplification System.

11. XLR OUT – This low impedance, XLR connector drives a pre EQ, balanced output signal for connecting directly to one of the balanced microphone inputs on a mixing console, either in studio or stage applications.

12. (Output) LEVEL - This control adjusts the general output level of the powered speaker, before equalization.

EQUALIZER SECTION

13. TREBLE - This ± 12 dB gain control determines the amount of high frequencies in the output signal. Turning the knob clockwise will boost the high frequencies while turning it anticlockwise will cut the high frequencies of the original output signal.

14. BASS - This ± 12 dB gain control determines the amount of low frequencies in the output signal. Turning the knob clockwise will boost the low frequencies while turning it anticlockwise will cut the low frequencies of the original output signal.

15. CLIP LED - This red LED begins to flash when the signal to the output power stage(s) becomes too loud. When permanently lit up, it indicates distortion that could be harmful for the speakers. This means that one or more of the Mic, Line, or Overall levels is set too high and should be at once re-adjusted until the led flashes again or shuts off.

MAINS SECTION

16. POWER SWITCH - This switch turns the amplified speaker on or off.

17. POWER LED - When this green LED is lit, the device is powered and ready to work. When it is off, it means the amplifier is switched off.

18. AC LINE SELECT - All SMS powered speakers (except the SMS12PLCD) are fitted with a switch enabling the unit to work on two different AC mains outlets: either 110-120VAC or 220-240VAC, as appropriate. Access to the selector is done by unscrewing the safety cover. Please mind the switch is set on the right AC Voltage position: either 115VAC or 230VAC, before powering up the unit.

19. POWER FUSE - In the event of the power fuse having to be replaced, first unplug the power cable from the mains outlet. Then remove the fuse cover and replace the power fuse with one of the same type and value. Never plug the power cable back into the mains outlet without the fuse cover. When powering on the amplifier, if the power fuse blows up again, go to a suitable service centre for repair.

20. AC (MAINS) INPUT - This is the input socket into which the moulded mains power cable must be connected. If the socket outlets available are not suitable for the plug supplied with this equipment, use an appropriate plug adapter that can handle the power required for this powered speaker.

MP3 READER/PLAYER (SMS 12 AND 15PLCD ONLY)

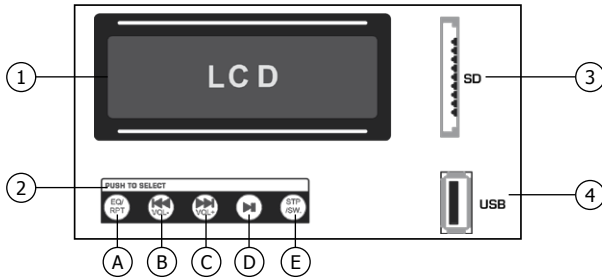

1. LCD: This large, blue LCD screen displays all relevant information about the function being selected or the MP3 file (or song) being played.

2. FUNCTION SELECTOR: This section provides front-selectable push switches, allowing you to choose between one of the 5 main functions requested when using the MP3 reader.

A. Repeat/ EQ

- Press this button once to play the current song repeatedly until the "stop" step is activated.
- Press this button twice and all loaded songs will be played one after the other until the "stop" step is selected.
- Press this button a third time to stop the repeating process.
- Press and hold this button to select among different types of equalization applied to the song currently playing.

B. Previous/ Vol -

- Press this button once to come back to the previous song.
- Press and hold this button to lower the volume of the MP3 reader.

C. Next/ Vol +

- Press this button once to go to the next song.
- Press and hold this button to increase the volume of the MP3 reader.

D. Play/ Pause

- Press this button to play the chosen song. Press it again to momentarily interrupt the playing. Press a third time to continue the reading of the song.

E. Stop SW

- Press this button to end the song.

3. SD (Input): This slot is used to insert a SD (Secured Digital), non-volatile memory card with MP3 files to be read.

4. USB (Input): In this port, plug in any USB (Universal Serial Bus) memory stick with MP3 files to be played.

REMOTE CONTROL (SMS12 AND 15PLCD, ONLY)

This device features all necessary push-switch selectable functions to easily operate your MP3 reader at a distance of up to 3 metres (approximately 9.8 feet) from your audio installation. For details, please refer to the functions explained above on this page in paragraph n°2 (FUNCTION SELECTOR), unless otherwise specified. The remote control included with your product may vary from the one pictured here, depending on the region where it was originally purchased.

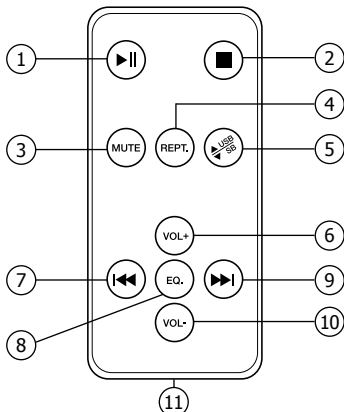

1. PLAY/PAUSE (see 2.D.)

2. STOP (see 2.E.)

3. MUTE – Mutes the sound from the MP3 player.

4. REPEAT (see 2.A.)

5. USB/SD SELECT - Use this button to choose among both audio file memory sources available: either the SD card or the USB stick.

6. VOLUME + (see 2.C.)

7. BACK (see 2.B.)

8. EQ SELECT (see 2.A.)

9. FORWARD (see 2.C.)

10. VOLUME - (see 2.B.)

11. BATTERY - The remote control unit needs a CR2025 button-cell battery to operate. In case of malfunction, always replace with the same type of battery. Dispose properly of the used battery for waste and recycling purposes.

TECHNICAL SPECIFICATIONS

Powered Speaker Model	SMS8P SMS8P USA	SMS10P SMS10P USA	SMS12P SMS12P USA
Max. Rated Power	90W RMS	160W RMS	200W RMS
Amplifier System	Bi-Amp	Bi-Amp	Bi-Amp
Woofers (Ø / P / Z)	8" (20cm)/ 70W/ 4Ω	10" (25cm)/ 115W/ 4Ω	12" (30cm)/ 215W/ 4Ω
Ferrite Driver (Voice Coil Size/Magnet Weight)	38mm (1.5")/ 30oz (850g)	50mm (2")/ 40oz (1.13kg)	50mm (2")/ 40oz (1.13kg)
	Steel frame	Steel frame	Steel frame
Compression Horn Tweeter			
Titanium Diaphragm (Ø / P / Z)	25mm (1")/ 30W/ 8Ω	34mm (1.3")/ 35W/ 8Ω	34mm (1.3")/ 35W/ 8Ω
Cross-over	Electronic	Electronic	Electronic
Frequency Response (@ -3dB)	50Hz to 20kHz	50 Hz to 20kHz	45 Hz to 20kHz
Total Harmonic Distortion	0.2% THD	0.3% THD	0.3% THD
Signal to Noise Ratio (@ max Rated Power)	-97dB	-96dB	-94dB
MIC Channel Inputs			
Balanced XLR Impedance	1.2kΩ	1.2kΩ	1.2kΩ
Sensitivity	4.5mV	2.5mV	2.5mV
Stereo Jack Impedance	1.2kΩ	1.2kΩ	1.2kΩ
Sensitivity	4.5mV	2.5mV	2.5mV
LINE Channel Inputs			
L + R Cinch Impedance	52kΩ	55kΩ	52kΩ
Sensitivity	120mV	56mV	56mV
Balanced XLR Impedance	10kΩ	10kΩ	10kΩ
Sensitivity	130mV	60mV	60mV
EQ Section Bass /Treble	± 12dB	± 12dB	± 12dB
Line Output (@ 1 kHz) Impedance	2kΩ	2kΩ	2kΩ
Max Gain	+9.5dB	+7dB	+6.5dB
Max level	3V	2.4V	2V
Maximum Input Level (before clip)	120mV	60mV	60mV
Sound Pressure Level (@ 1kHz)			
(or Sensitivity in dB for 1W Power @ 1m)	92dB 1W@1m	94.5dB 1W@1m	96.5dB 1W@1m
Mains Power Consumption	105W	140W	172W
Mains Power Fuse (110V-130V/ 60Hz)	T 2.5A	T 3.15A	T 3.15A
Mains Power Fuse (220V-240V/ 50Hz)	T 1.0A	T 1.6A	T 2.0A
Dimensions (H x L x P)	38.5 x 28 x 22cm	47 x 34.5 x 27cm	55.5 x 40 x 31.5cm
Dimensions (H x W x D)	15.2 x 11 x 8.7in	18.5 x 13.6 x 10.6in	21.9 x 15.7 x 12.4in
Weight	8.5kg/ 18.7lbs	13.7kg/ 30.2lbs	18.3kg/ 40.3lbs

Features and Specifications are subject to change without notice.

TECHNICAL SPECIFICATIONS

Powered Speaker Model	SMS15P SMS15P USA	SMS12PLCD SMS12PLCD USA	SMS15PLCD SMS15PLCD USA
Max. Rated Power	220W RMS	180W RMS	200W RMS
Amplifier System	Bi-Amp	Mono Amp	Mono Amp
Woofers (Ø/ P/ Z)	15" (38 cm)/250W/ 4Ω	12" (30 cm)/215W/ 4Ω	15" (38 cm)/250W/ 4Ω
Ferrite Driver (Voice Coil Size/Magnet Weight)	38mm (1.5")/30oz (850g)	75.5mm (3")/60oz (1.7kg)	60mm (2.4")/50oz (1.41kg)
	Steel frame	Steel frame	Steel frame
Compression Horn Tweeter			
Titanium Diaphragm (Ø/ P/ Z)	25mm (1")/ 30W/ 8Ω	44mm (1.7")/ 50W/ 8Ω	34mm (1.3")/ 35W/ 8Ω
Cross-over	Electronic	Passive	Passive
Frequency Response (@ -3dB)	40Hz to 20kHz	45Hz to 20kHz	40Hz to 20kHz
Total Harmonic Distortion	0.3% THD	0.3% THD	0.3% THD
Signal to Noise Ratio (@ max Rated Power)	-94.5dB	-95dB	-94.5dB
MIC Channel Inputs			
Balanced XLR Impedance	1.2kΩ	1.2kΩ	1.2kΩ
Sensitivity	4mV	2.5mV	4mV
Stereo Jack Impedance	1.2kΩ	1.2kΩ	1.2kΩ
Sensitivity	4mV	2.5mV	4mV
LINE Channel Inputs			
L + R Cinch Impedance	55kΩ	52kΩ	55kΩ
Sensitivity	150mV	56mV	150mV
Balanced XLR Impedance	10kΩ	10kΩ	10kΩ
Sensitivity	170mV	60mV	170mV
EQ Section Bass /Treble	± 12dB	± 12dB	± 12dB
Line Output (@ 1 kHz) Impedance	2kΩ	2kΩ	2kΩ
Max Gain	+10dB	+6.5dB	+10dB
Max level	3V	2V	3V
Maximum Input Level (before clip)	160mV	60mV	160mV
Sound Pressure Level (@ 1kHz)			
(or Sensitivity in dB for 1W Power @ 1m)	97.5dB 1W@1m	96.5dB 1W@1m	97.5dB 1W@1m
Mains Power Consumption	190W	172W	190W
Mains Power Fuse (110V-130V/ 60Hz)	T 5.0A	T 3.15A	T 5.0A
Mains Power Fuse (220V-240V/ 50Hz)	T 2.5A	T 2.5A	T 3.15A
Dimensions (H x L x P)	66.5 x 44.5 x 40cm	55.5 x 40 x 31.5cm	66.5 x 44.5 x 40cm
Dimensions (H x W x D)	26.2 x 17.5 x 15.7in	21.9 x 15.7 x 12.4in	26.2 x 17.5 x 15.7in
Weight	25.4kg/ 56lbs	18.3kg/ 40.3lbs	25.4kg/ 56lbs

Features and Specifications are subject to change without notice.

DISTRIBUIDOR



www.staggmusic.com